

<b>Part Number</b> SDS-WM-RCW-ST	<b>Nominal Dimensions</b> 2" x 2" x 120"
<b>Description</b> <p>The wall-mounted 2" x 2" Secure Raceway encloses and protects secure network cables. The Secure Raceway comes in 10-foot sections in a 100' kit and comprises two pieces: the Raceway and TopCap. Manufactured mounting points on the Raceway allow a simplified, labor-saving mounting technique. With the addition of other locking components, the Raceway and TopCap securely lock together.</p>	
<b>Specifications</b> <ul style="list-style-type: none"> <li>• 16-gauge electro-galvanized steel</li> <li>• Components:           <ul style="list-style-type: none"> <li>– High Security Raceway: Length 120" x Width 1.9" x Height 1.8"</li> <li>– High Security TopCap: Length 120" x Width 2.0" x Height 1.8"</li> </ul> </li> <li>• Total length: 120" sections of Raceway and TopCap (10 each)</li> <li>• Total weight: 254 lbs Raceway and TopCap</li> <li>• Two (2) manufactured mounting points in each 120" raceway section           <ul style="list-style-type: none"> <li>– 1½" from ends of each 120" raceway</li> <li>– Located along raceway center line</li> </ul> </li> </ul> <p>Powder Coat Finish: White Textured</p>	

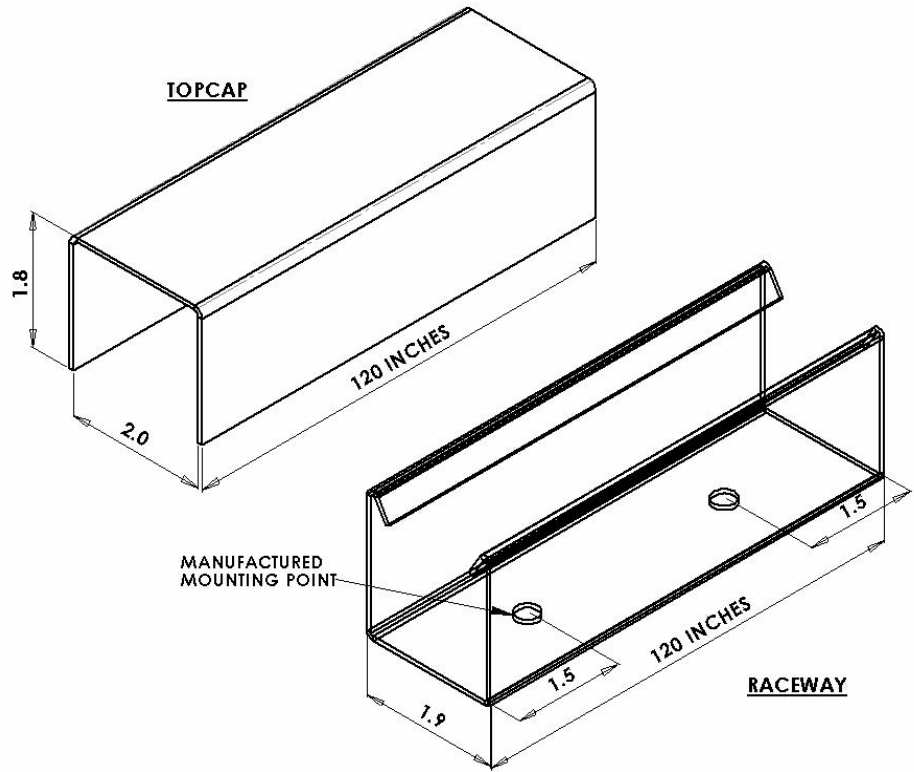

Holocom, Inc.  
 2386 Faraday Avenue, Suite 200  
 Carlsbad, CA 92008  
 Tel: (760) 804-9545 Fax: (760) 804-9149  
[www.holocom.com](http://www.holocom.com)

**PART #:**  
 SDS-WM-RCW-ST

**TITLE:**  
 SECURE RACEWAY - STEEL 100 FT

All material contained in this document is the property of Holocom, Inc. and may not be reproduced or transmitted (including electronically) without the written consent of Holocom, Inc. Holocom and the Holocom logo are registered trademarks of Holocom, Inc. Other noted marks are trademarks of their respective companies. Holocom products protected by US Pats. 7,183,488; 7,115,814; 7,053,303; 7,049,517; 6,838,616; 5,831,211 and Pats. pending. Made in the U.S.A. Copyright © 2008 Holocom, Inc. All rights reserved.