

| | |
|---------------------|---------------------------|
| Product Code | Nominal Dimensions |
| SDS-WM-RCW-AL | 2" x 2" x 120" |

Description

The wall-mounted 2" x 2" Aluminum Secure Raceway encloses and protects secure network cables. The Aluminum Secure Raceway comes in 10-foot sections in a 100' kit and comprises two pieces: the Raceway and TopCap. With the addition of other locking components, the Raceway and TopCap securely lock together.

Specifications

- .060" 6063-T5 Aluminum
- Components:
 - High Security Raceway: Length 120" x Width 1.9" x Height 1.8"
 - High Security TopCap: Length 120" x Width 2.0" x Height 1.8"
- Total length: 120" sections of Raceway and TopCap (10 each)
- Total weight: 100 lbs Raceway and TopCap

Powder Coat Finish: White Textured

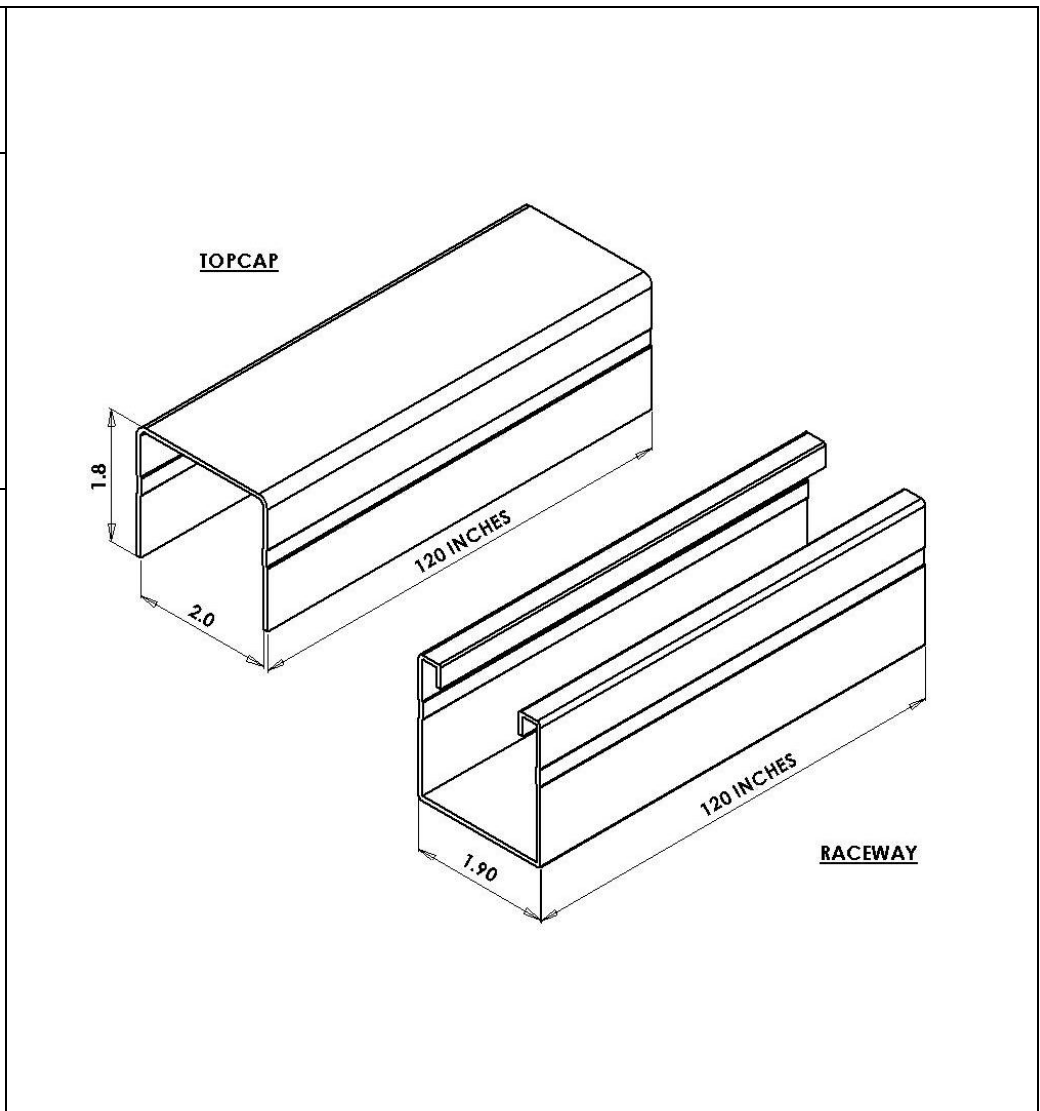

Holocom, Inc.
 2386 Faraday Avenue, Suite 200
 Carlsbad, CA 92008
 Tel: (760) 804-9545 Fax: (760) 804-9149
www.holocom.com

PRODUCT CODE:
SDS-WM-RCW-AL

TITLE:
SECURE RACEWAY – ALUMINUM

All material contained in this document is the property of Holocom, Inc. and may not be reproduced or transmitted (including electronically) without the written consent of Holocom, Inc. Holocom and the Holocom logo are registered trademarks of Holocom, Inc. Other noted marks are trademarks of their respective companies. Holocom products protected by US Pats. 7,183,488; 7,115,814; 7,053,303; 7,049,517; 6,838,616; 5,831,211 and Pats. pending. Made in the U.S.A. Copyright © 2008 Holocom, Inc. All rights reserved.