

Product Code	Nominal Dimensions
SLC-WM-RCW-ST-20	60" x 6" x 3.5"

Description

The new wall-mounted Secure Large Carrier™ offers a third Holocom cable carrier option for securing classified network cabling. Secure Large Carrier™ is constructed of 16-gauge electro-galvanized steel, and consists of Raceway, TopCap, and four (4) Secure Raceway Joints (SLC-RW-SRJ). Secure Large Carrier™ provides more than seven (7) times the cable capacity of industry standard Holocom SDS Secure Raceway, making it the perfect backbone carrier for home run cable design systems. Like SDS Secure Raceway, it uses the patented Holocom locking system enabling users to make moves, adds, and changes. One manufactured mounting point at each end of the raceway allows simplified, labor-saving installation.

- Specifications**
- 16-gauge electro-galvanized steel
 - Components:
 - Raceway: Length 59" x Height 6" x Width 3.4"
 - TopCap: Length 59" x Height 2" x Width 1.8"
 - Secure Raceway Joint: Four (4)
 - Max 200 CAT 6 cable capacity
 - Integrates with SDS Secure Raceway & Secure Mini Dukt™
 - One manufactured mounting point 1.5" from each raceway end
 - Supplied in 5' sections in a 20' kit
 - Total kit weight: 97 pounds
- Powder Coat Finish: White Textured

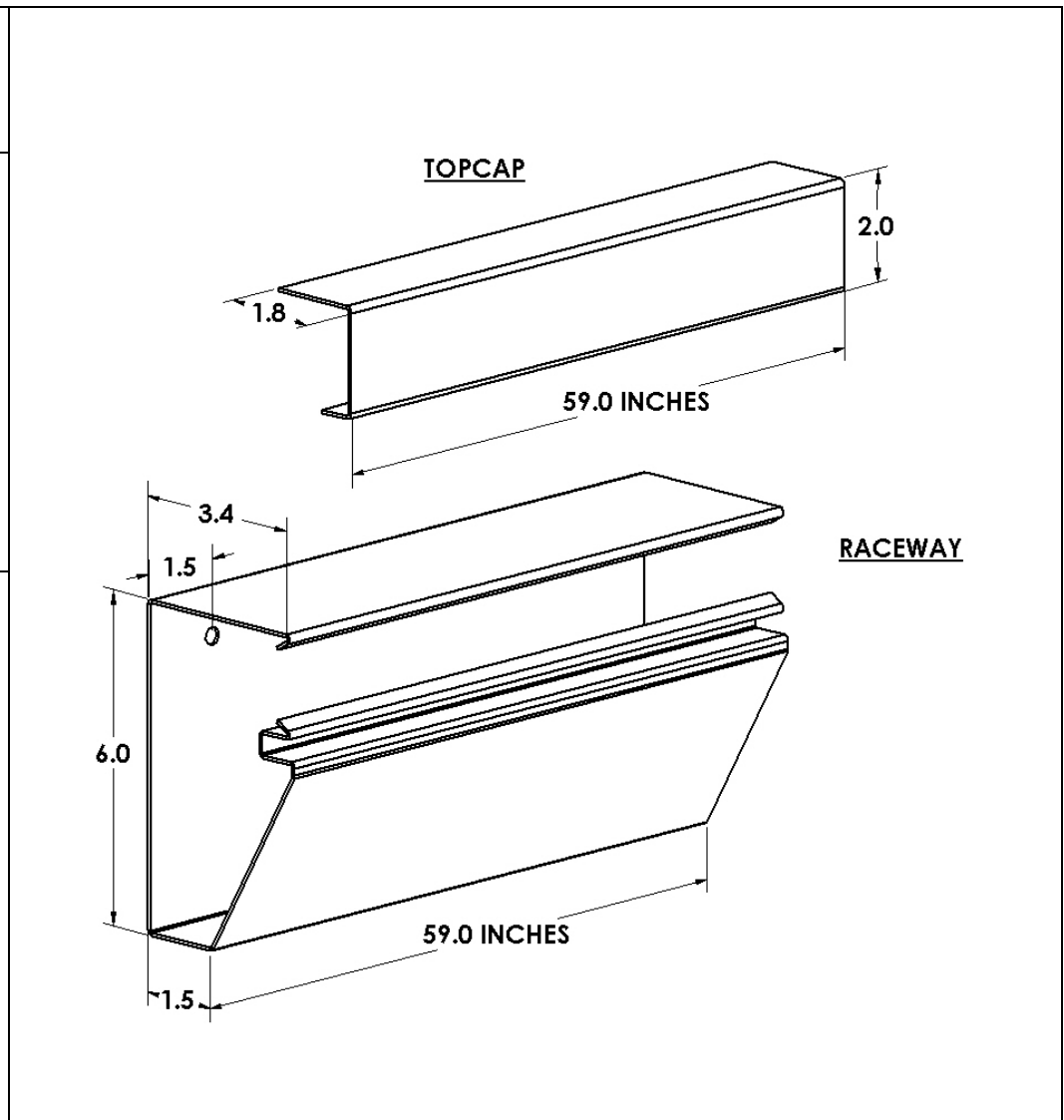

Holocom, Inc.
www.holocom.com

PRODUCT CODE:
SLC-WM-RCW-ST-20

All material contained in this document is the property of Holocom, Inc. and may not be reproduced or transmitted (including electronically) without the written consent of Holocom, Inc. Holocom and the Holocom logo are registered trademarks of Holocom, Inc. Other noted marks are trademarks of their respective companies. Holocom products protected by US Pats. 7,183,488; 7,115,814; 7,053,303; 7,049,517; 6,838,616; 5,831,211 and patents pending.
 Made in the U.S.A. Copyright © 2011 Holocom, Inc. All rights reserved.

TITLE:
**SECURE LARGE CARRIER™
 RACEWAY & TOPCAP KIT**